



From Signal-based to Impedance-based Sensing: A Paradigm Shift for Plug-and-play, Mobile, and Sensitive Battery-free Sensing

Liyao Li¹, Yun Wu², Minsung Kim³, Bozhao Shang², Jie Xiong⁴, Wenyao Xu¹,
Xiaojiang Chen², Yaxiong Xie¹

¹University at Buffalo, SUNY, ²Northwest University
³Rutgers University, ⁴Nanyang Technological University

Battery free Wireless sensing

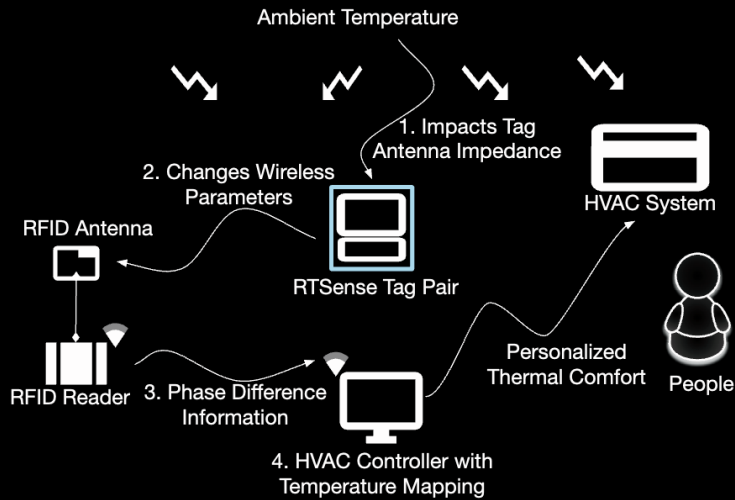

RTSense [SenSys '20]:
Temperature sensing

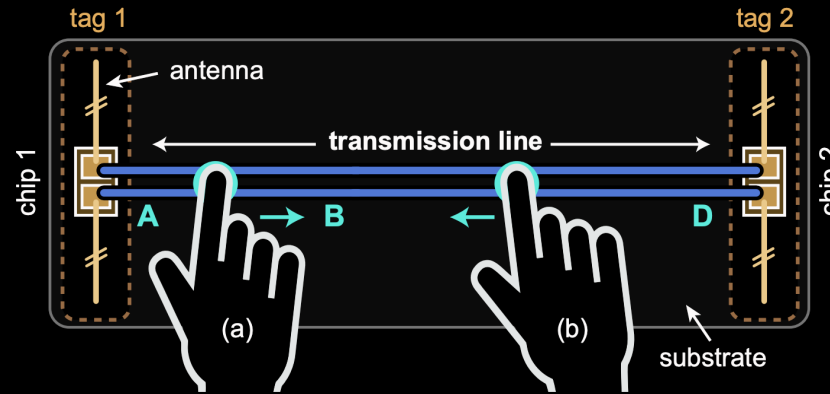
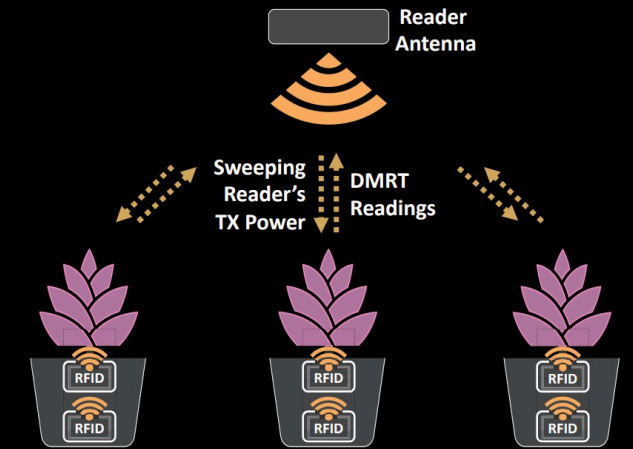
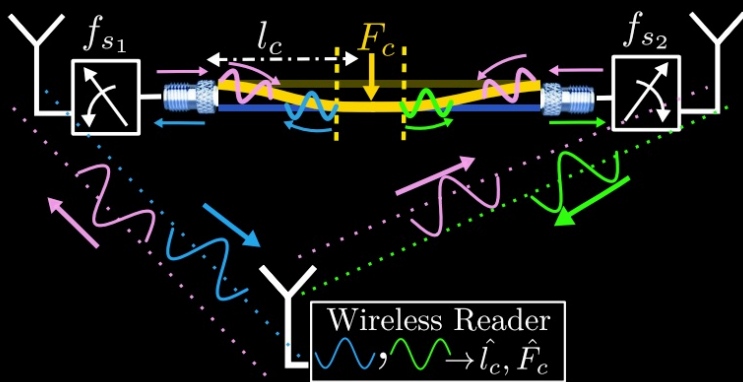

Figure Input sensing [Sensys '20]



Soil Moisture sensing [MobiSys '20]



WiForce [NSDI '22]: Tracking and
measuring force

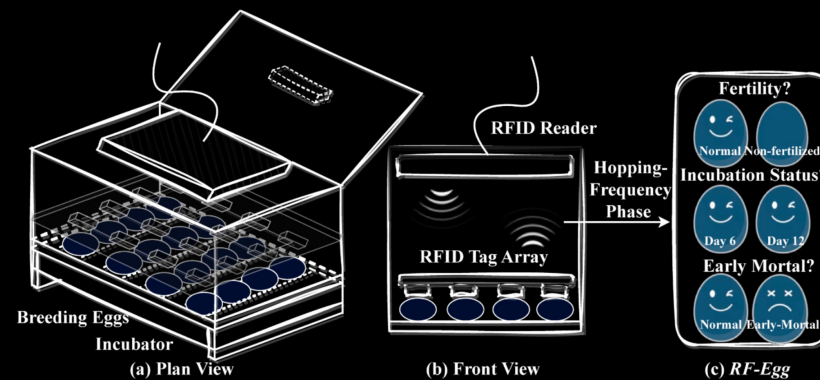

RF-Egg [Mobicom '25]: Egg incubation
sensing

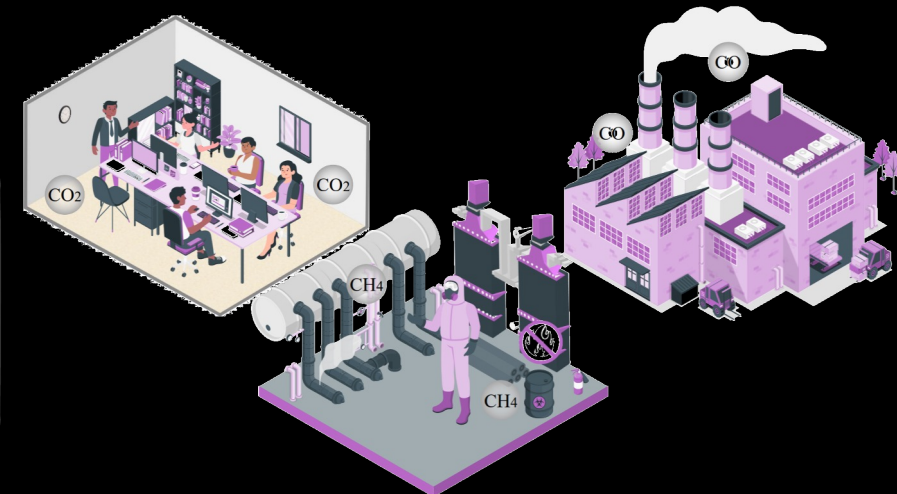

Gastag [Mobicom '25]: Sensing gas
concentration

Battery-free Communication: Backscatter

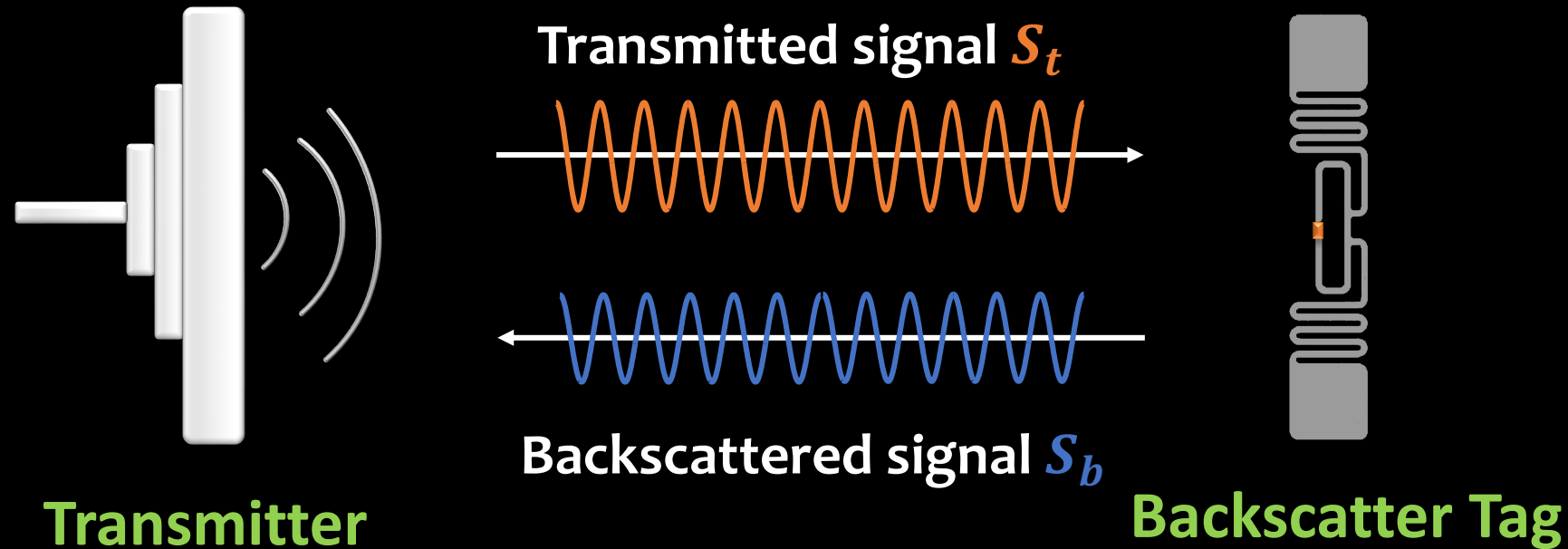

Backscatter-based Sensing

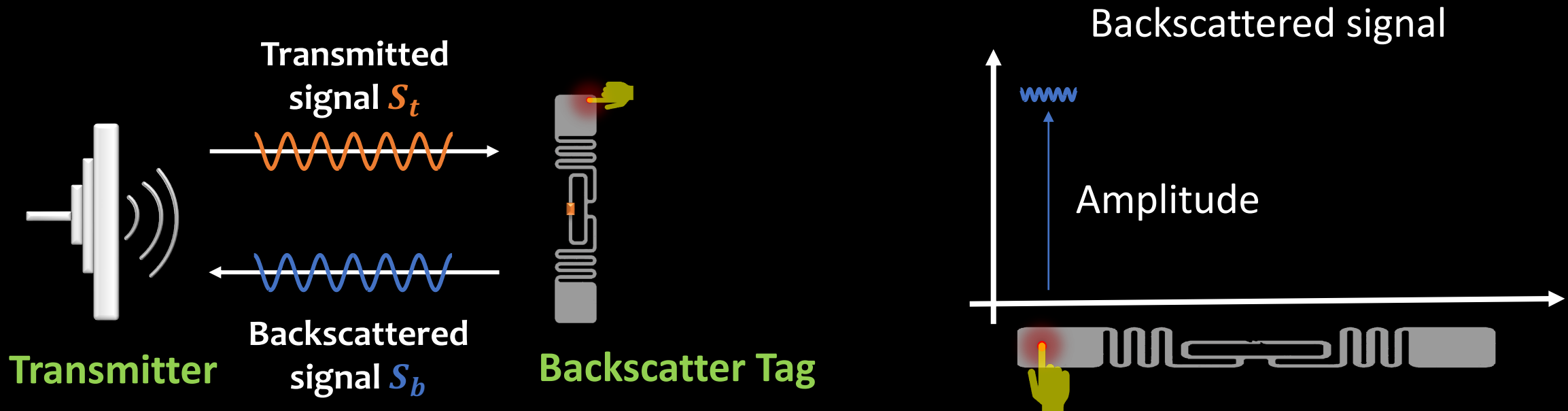

Backscatter-based Sensing

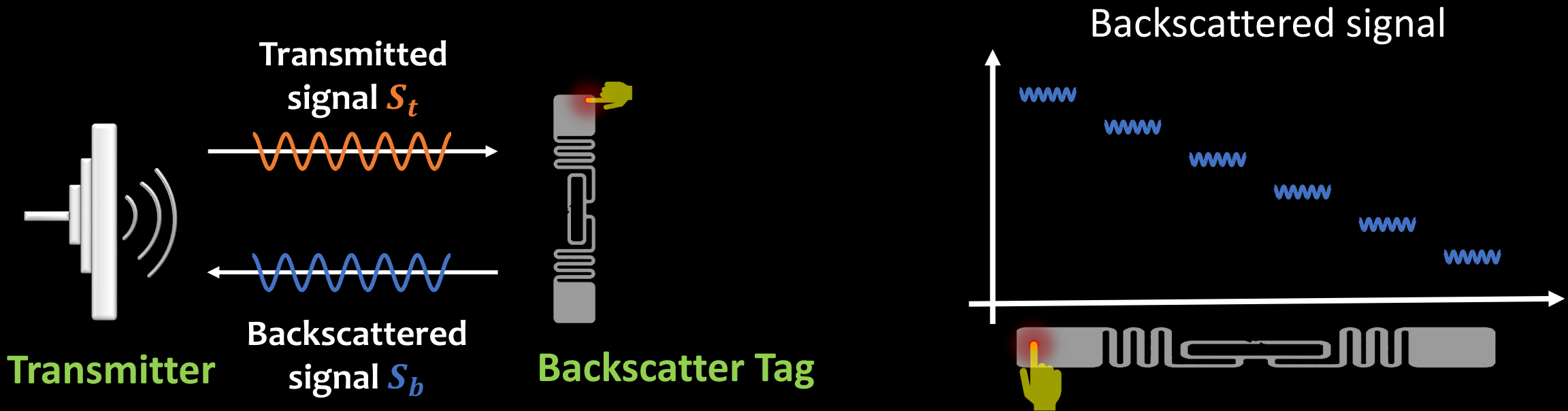

Backscatter-based Sensing

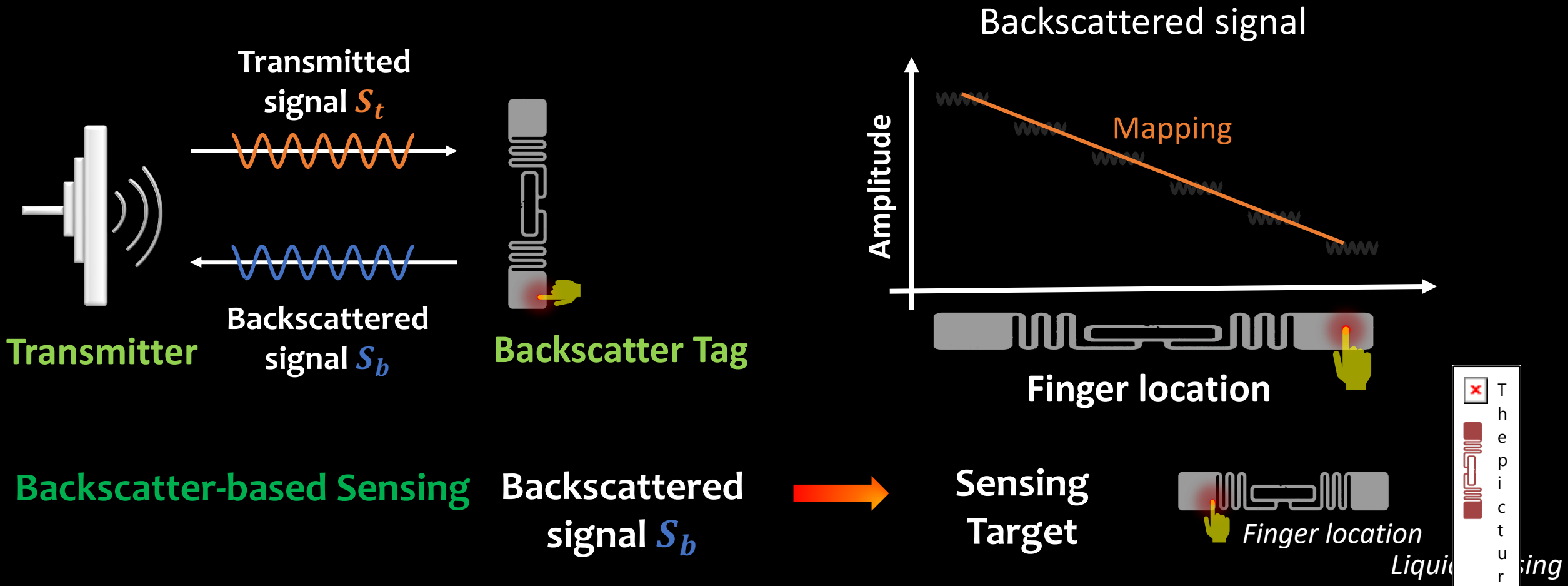

Challenges of Backscatter-based Sensing: *Interference*

Backscatter-based Sensing

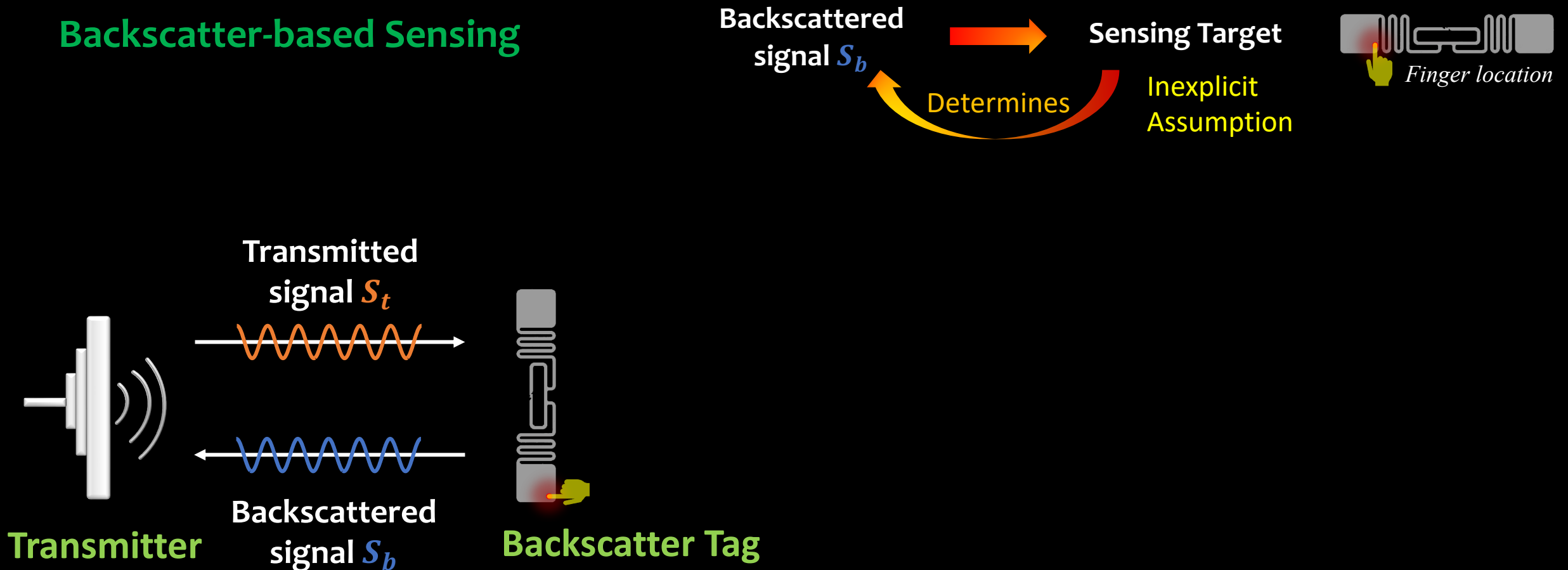

Challenges of Backscatter-based Sensing: *Interference*

Backscatter-based Sensing

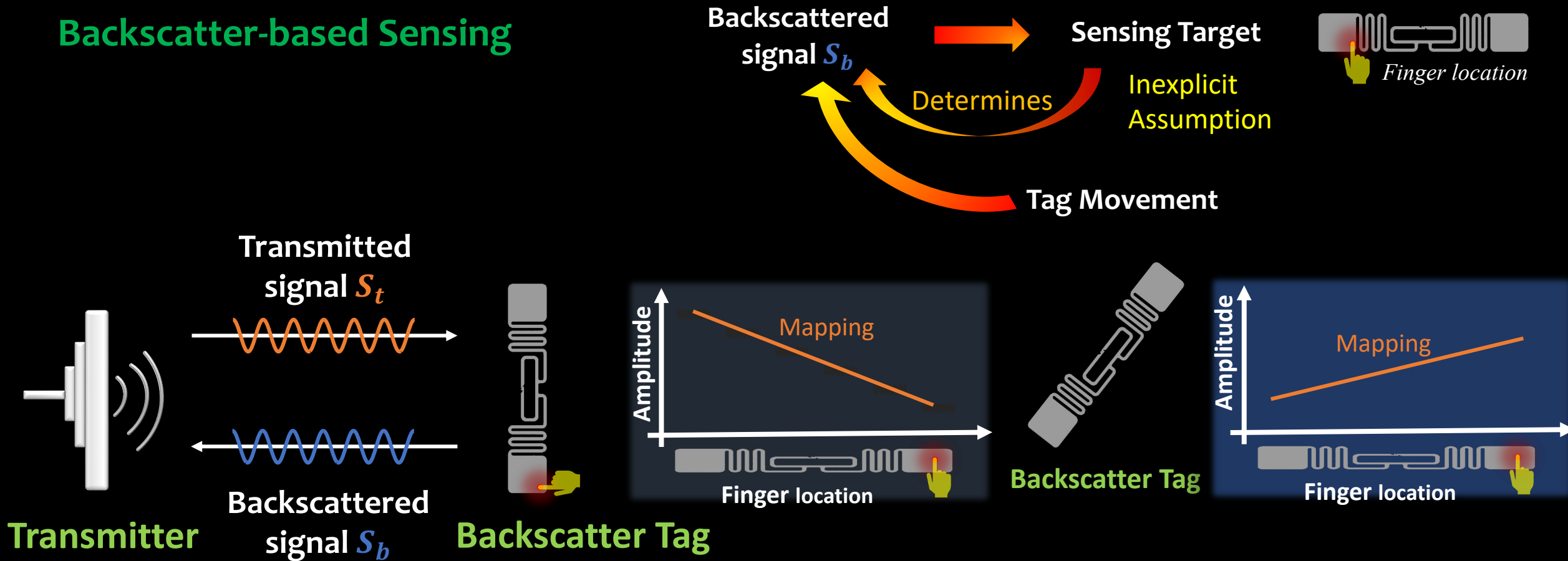

Challenges of Backscatter-based Sensing: *Interference*

Backscatter-based Sensing

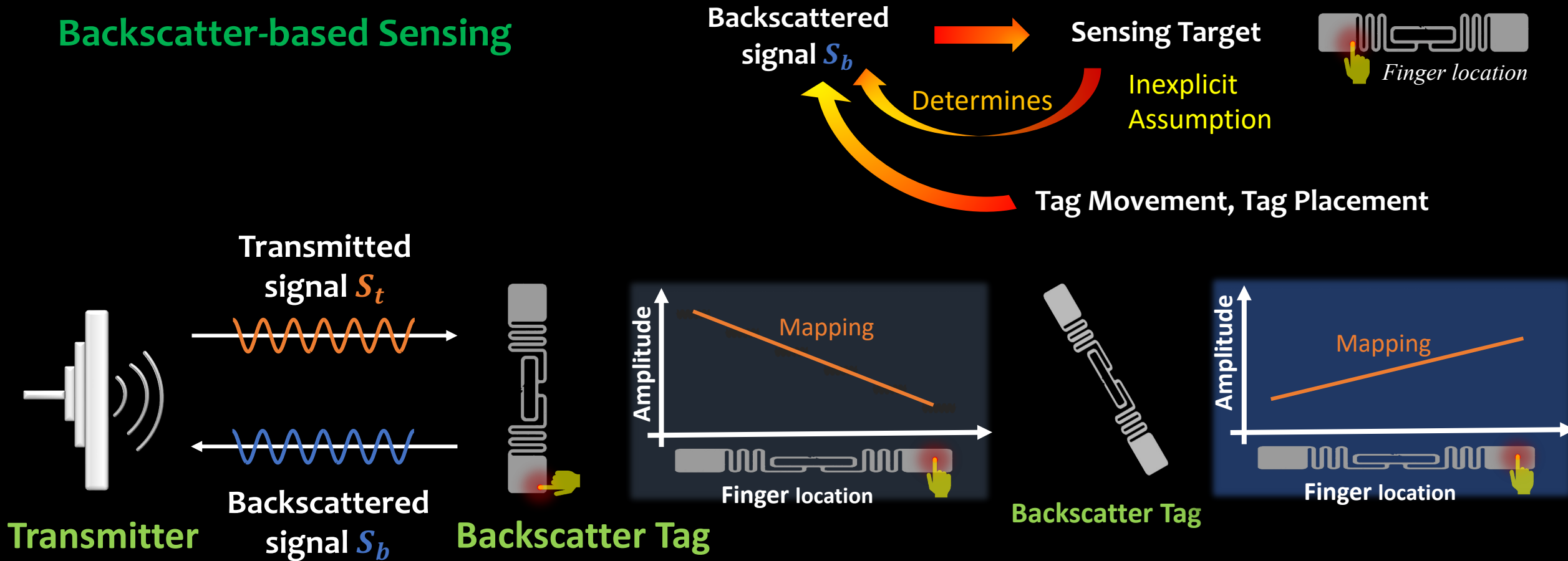

Challenges of Backscatter-based Sensing: *Interference*

Backscatter-based Sensing

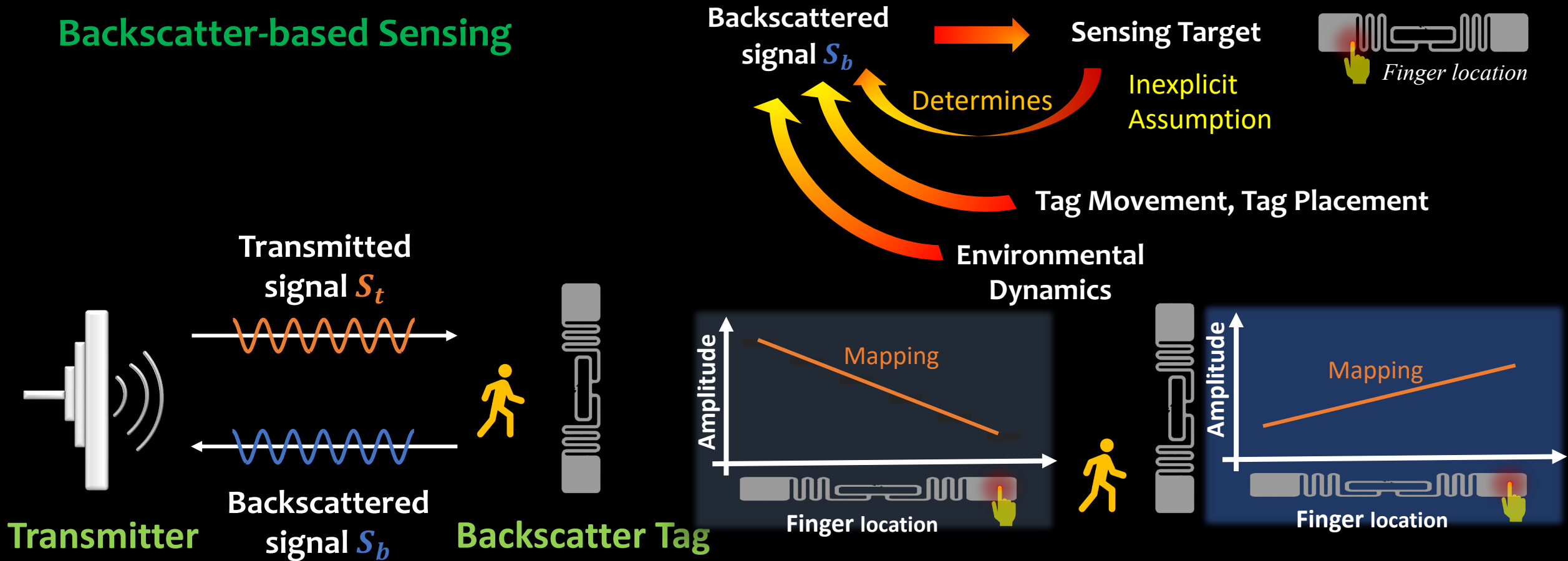

Challenges of Backscatter-based Sensing: *Interference*

→ *Existing Solutions : Reference tag*

Backscatter-based Sensing

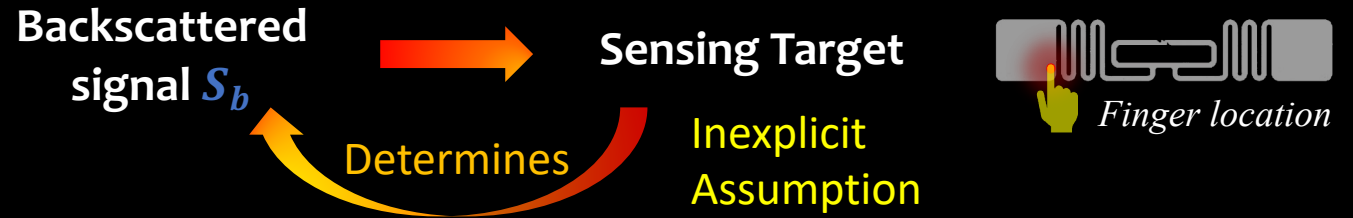

Reference Tag

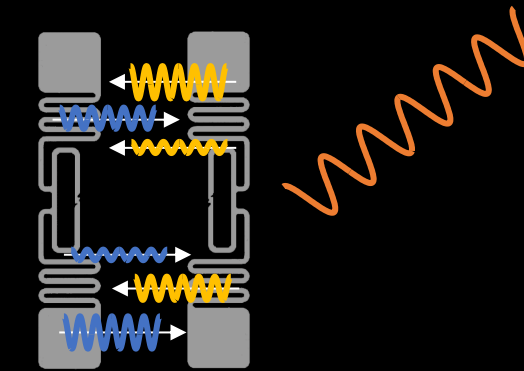
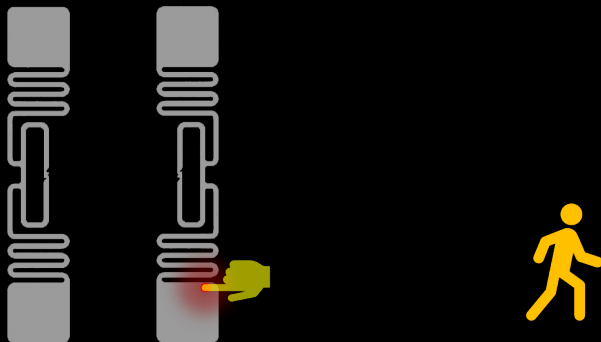

Mutual Coupling

- Mutual coupling changes the signal and thus signal difference
- Mutual coupling varies with tag motion, placement and channel dynamics

Measure the signal difference

Challenges of Backscatter-based Sensing : *Interference*

→ *Existing Solutions: Power divider*

Backscatter-based Sensing

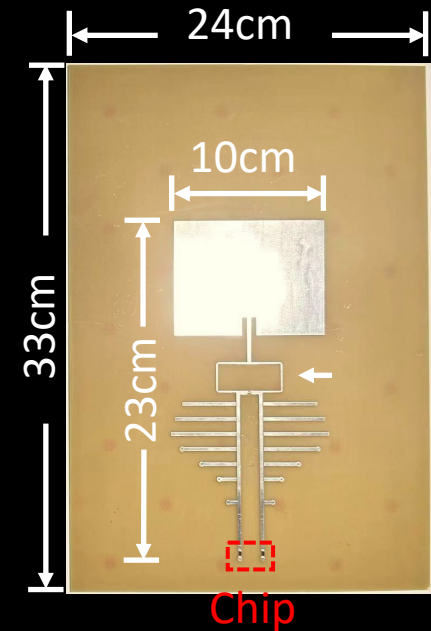
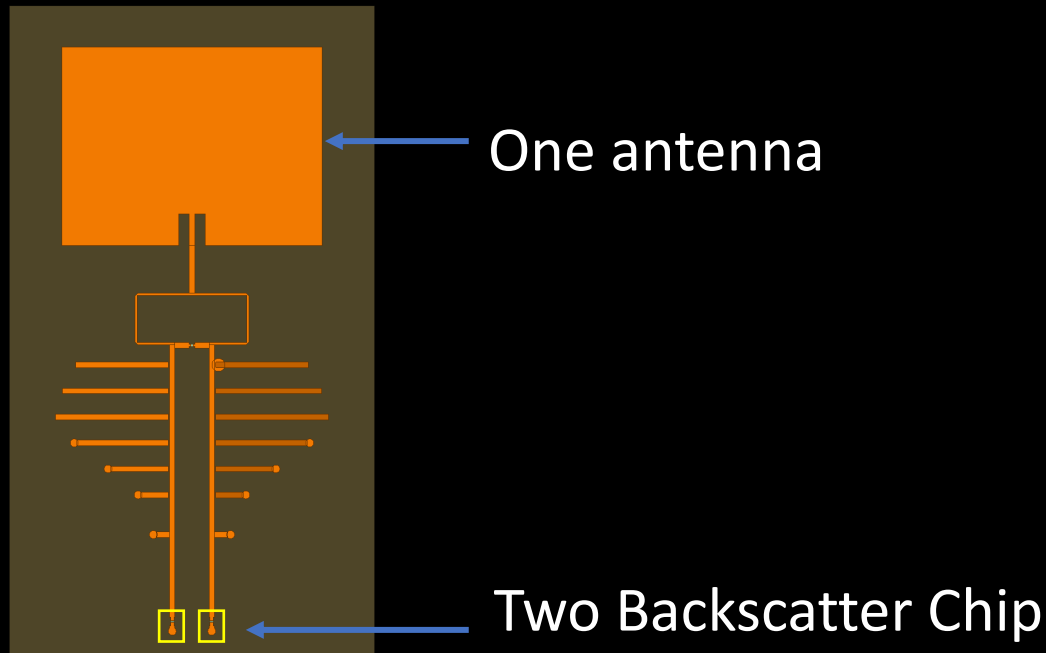
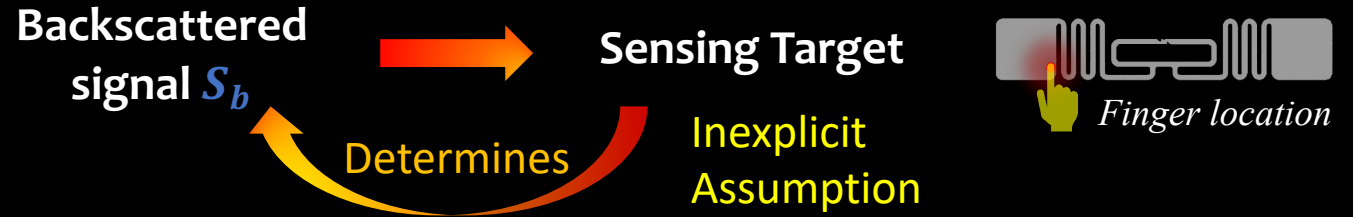

Challenges of Backscatter-based Sensing : *Interference*

→ *Existing Solutions : Power divider*

Backscatter-based Sensing

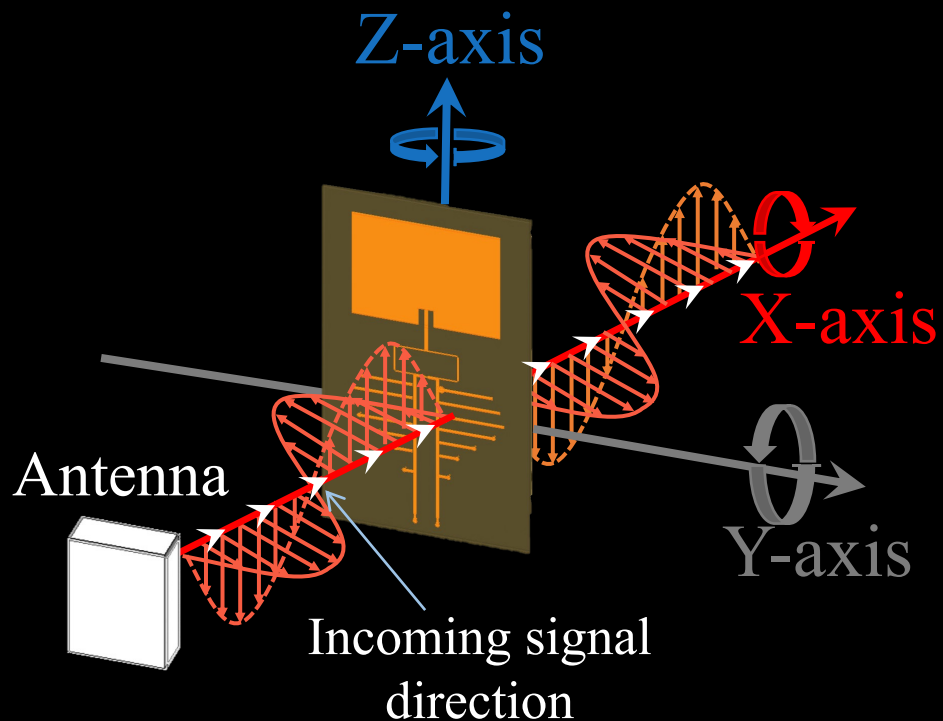

Backscattered signal S_b



Sensing Target

Determines

Inexplicit Assumption



- Bulky Tag
- Sensitive to Tag Orientation
- Reading Rates Drop with Distance & Rotation

Challenges of Backscatter-based Sensing: *Interference*

→ *Existing Solutions : Machine learning based*

Backscatter-based Sensing

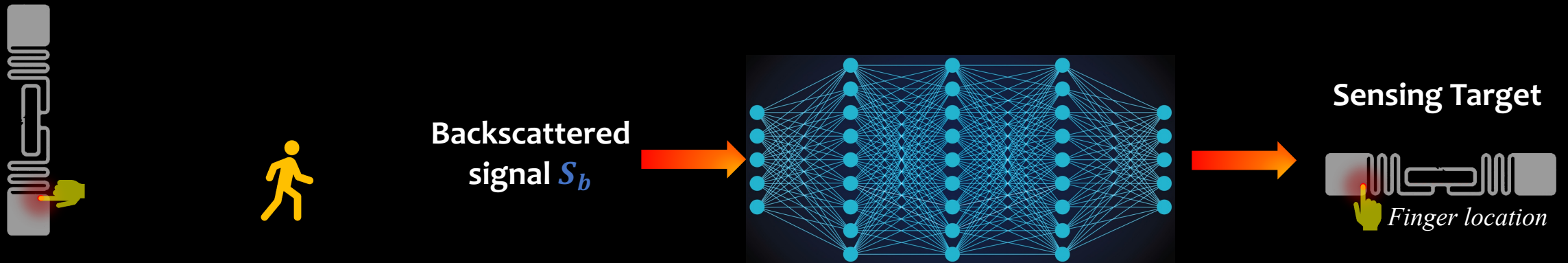
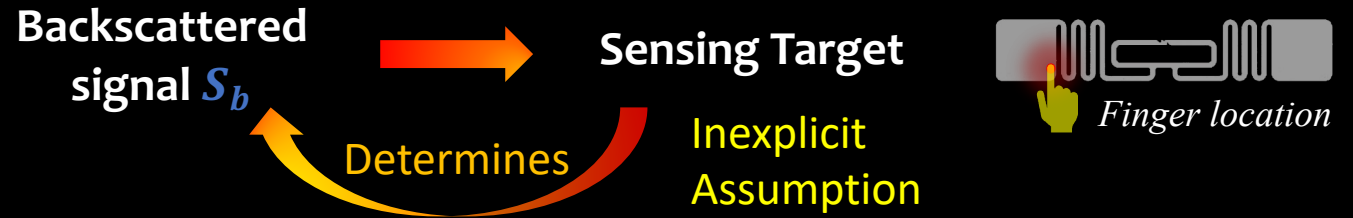

Paradigm-Shift: Impedance-based Sensing

Traditional Scheme

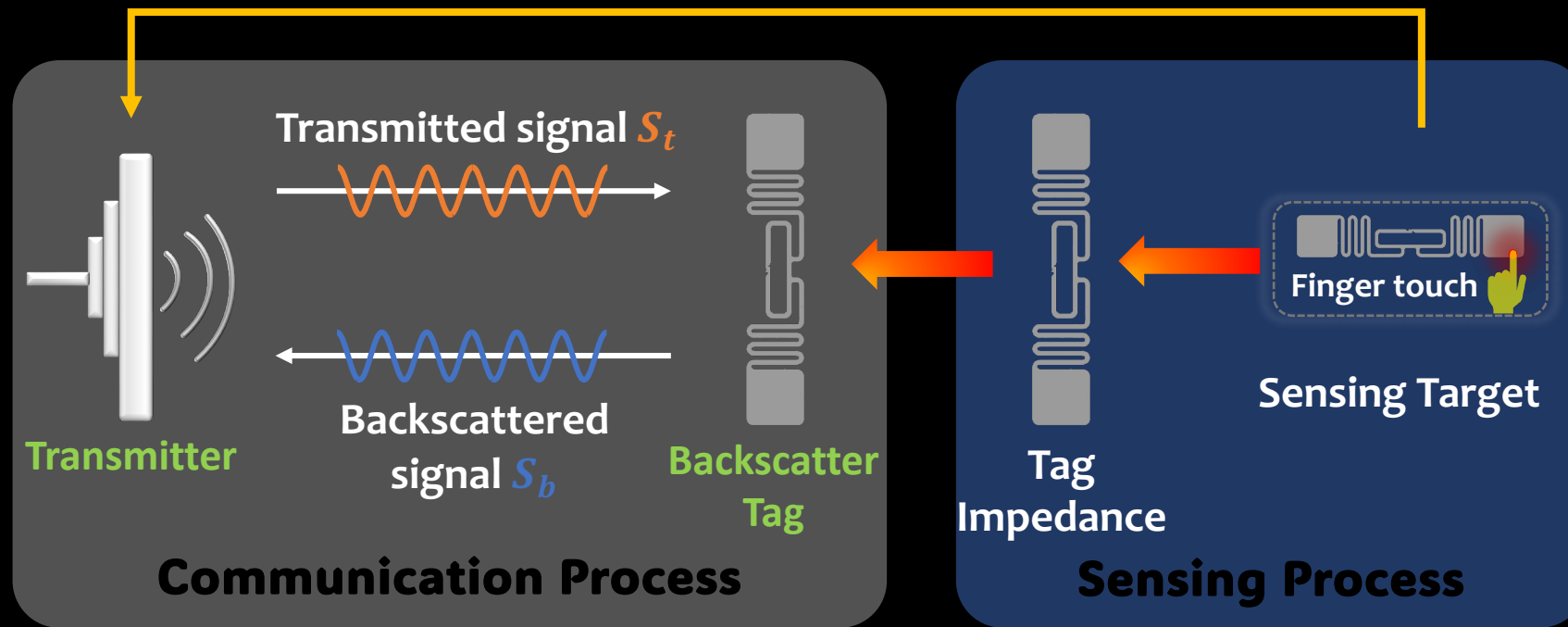

Paradigm-Shift: Impedance-based Sensing

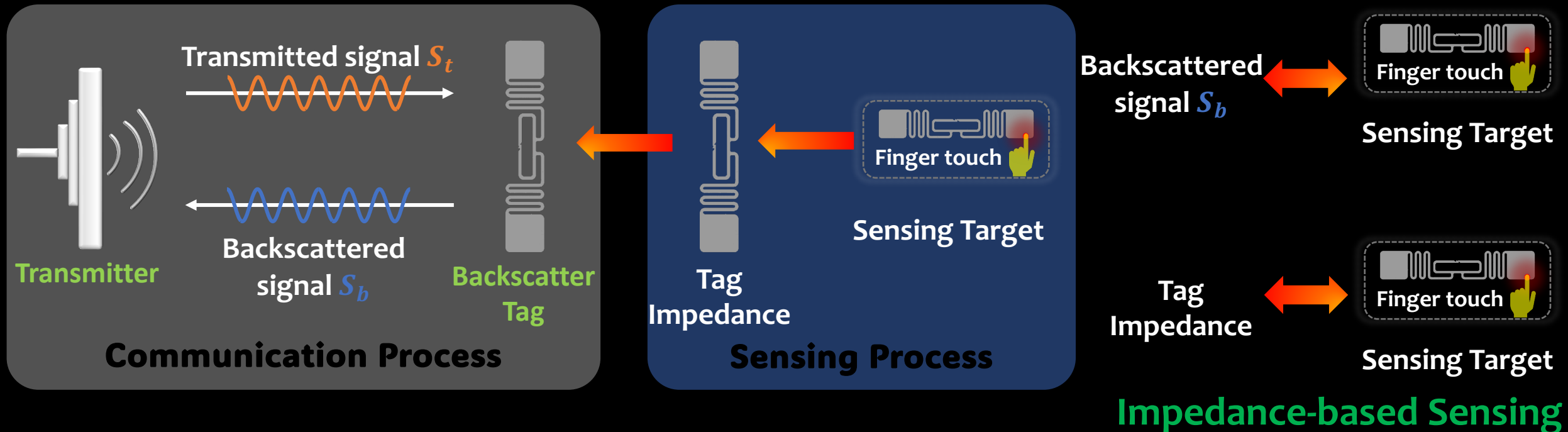

Paradigm-Shift: Impedance-based Sensing

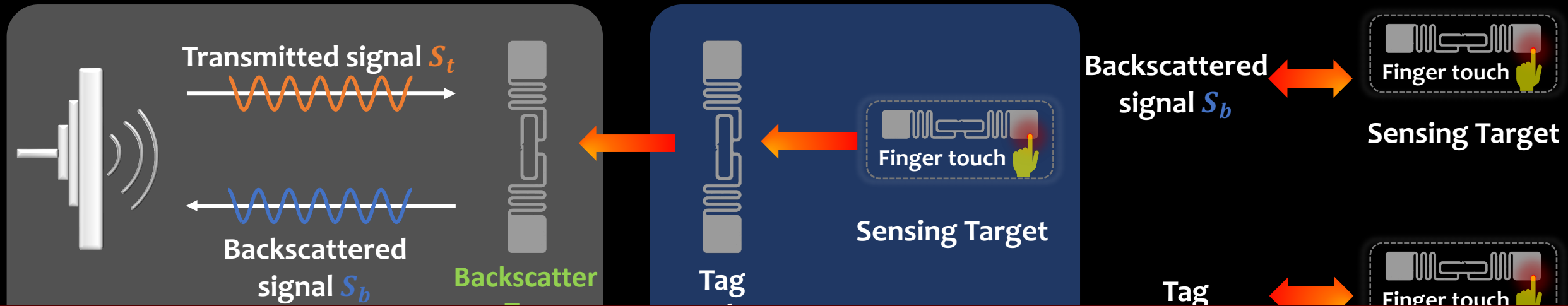

How can we **accurately measure** the impedance of the backscatter tag?

Impedance Matching

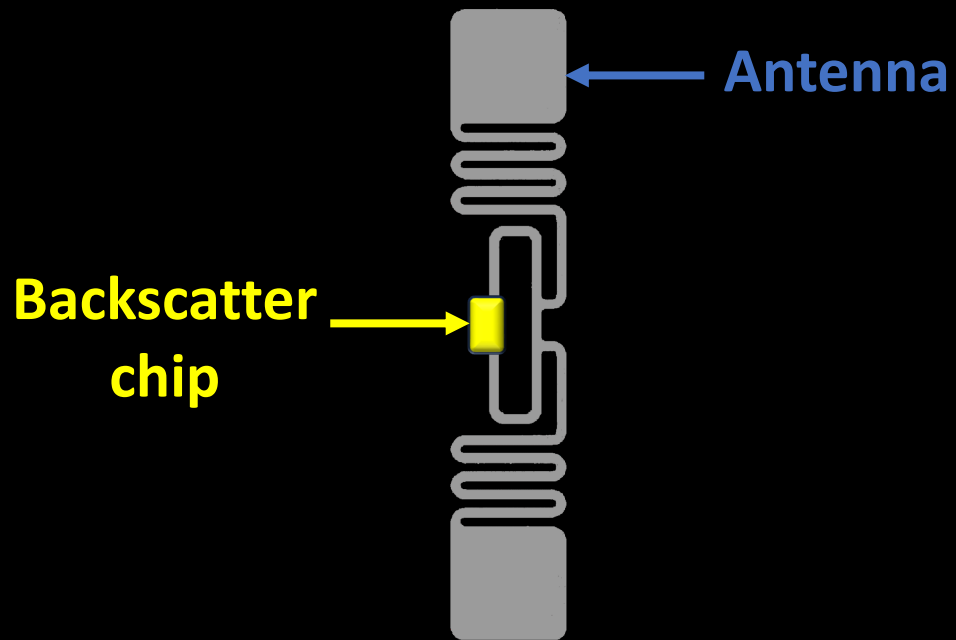

Wireless Communication Theory

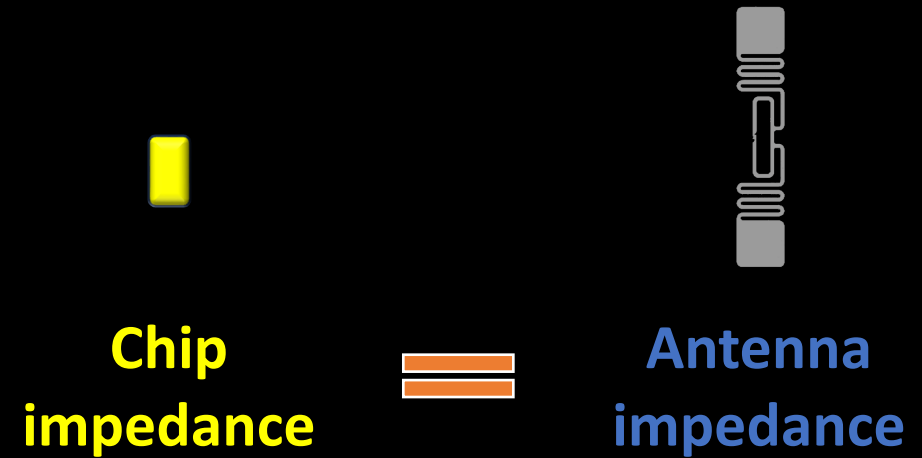

Antenna Impedance Varies with Sensing Targets

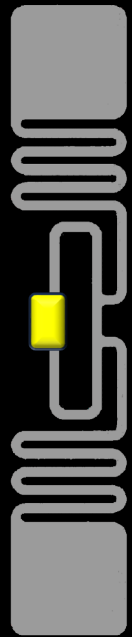

Wireless Communication Theory

**Chip
impedance**



**Antenna
impedance**

**Antenna
Impedance**

Dynamic Impedance Matching

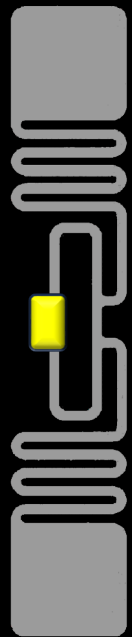

Wireless Communication Theory

Chip impedance

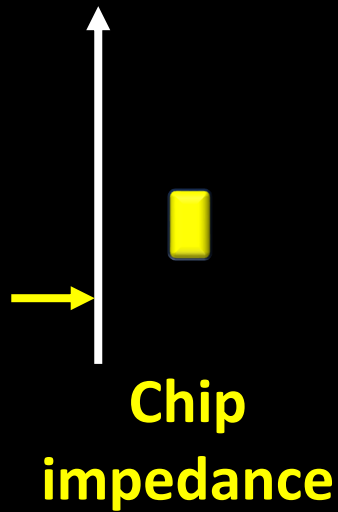

Antenna impedance

Antenna Impedance

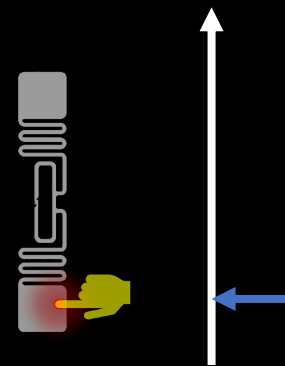

Dynamic Impedance Matching

Wireless Communication Theory

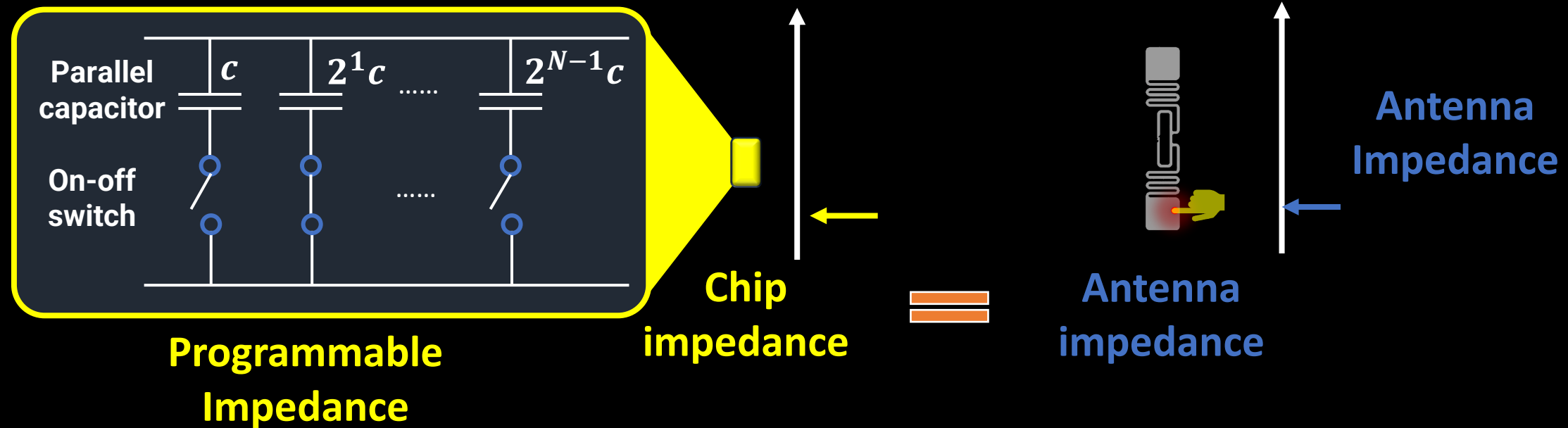

Dynamic Impedance Matching : OhmScanner

Wireless Communication Theory

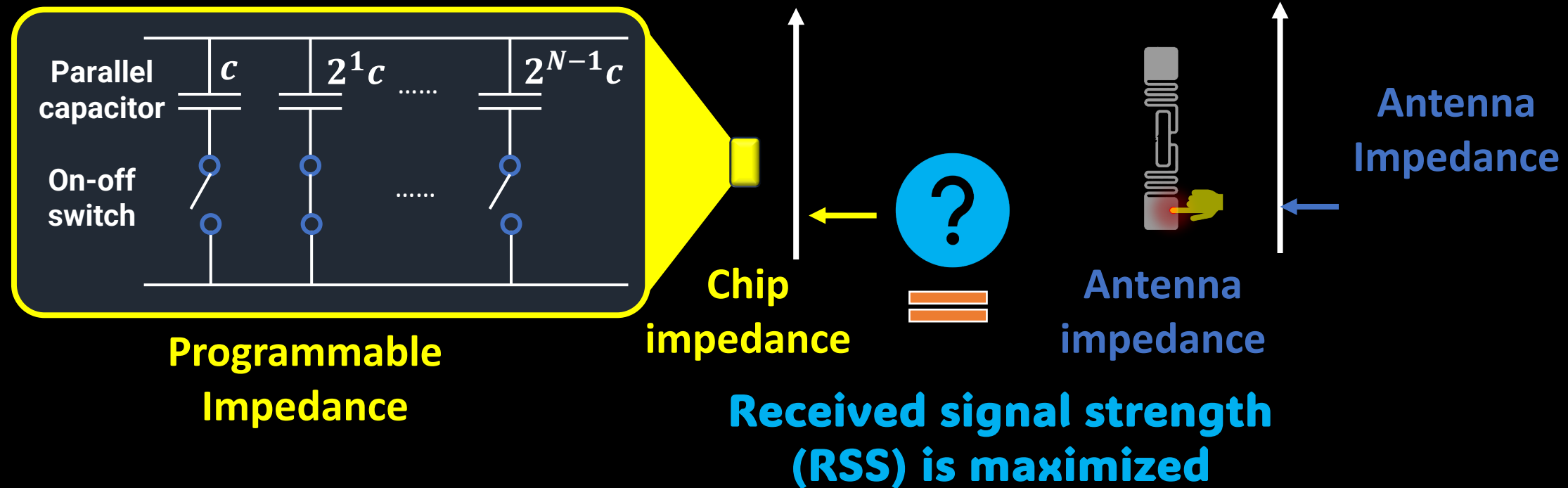

Comparing with Existing Application

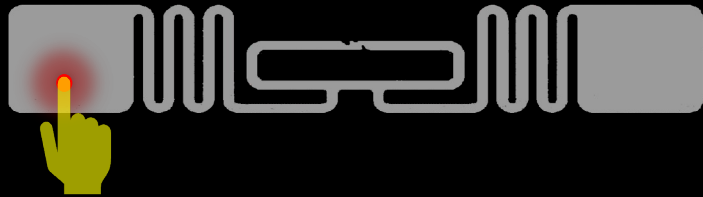

Tracking finger location

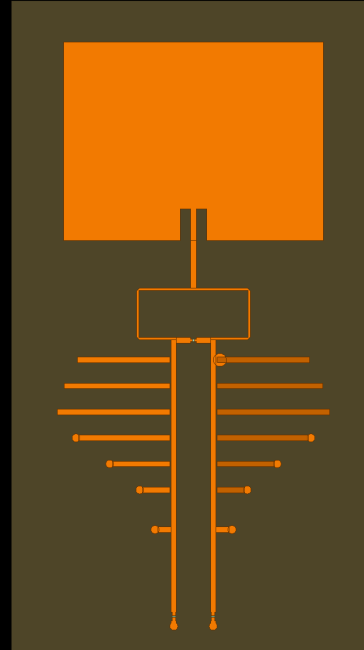

Keyboard



Liquid Sensing

New Applications

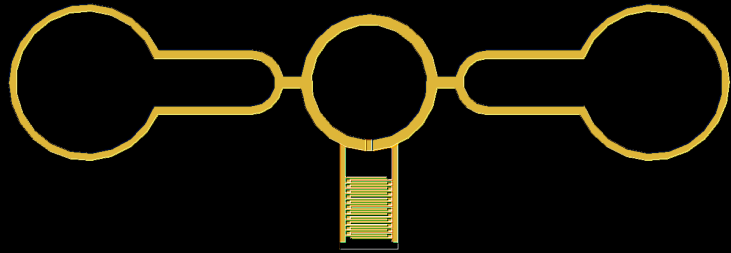

Liquid Concentration Sensing

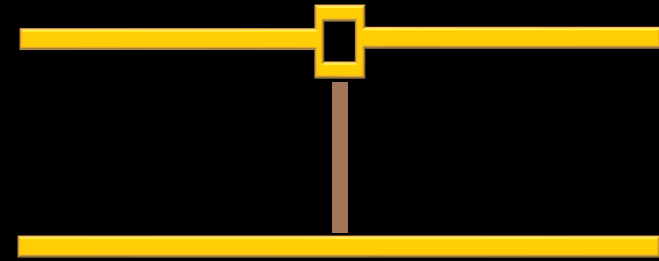

UV-Light Sensing



Pressure Sensing

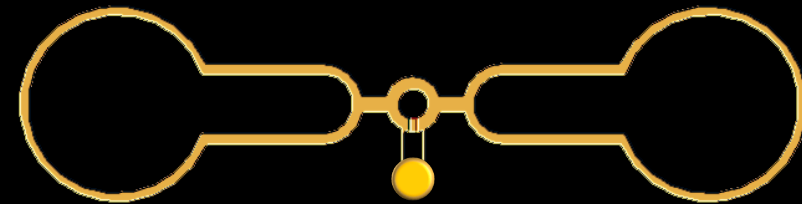

Temperature Sensing

New APP: Liquid Concentration Sensing

Interdigitated Structure

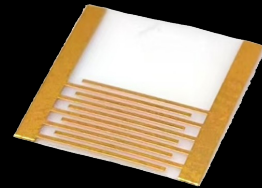
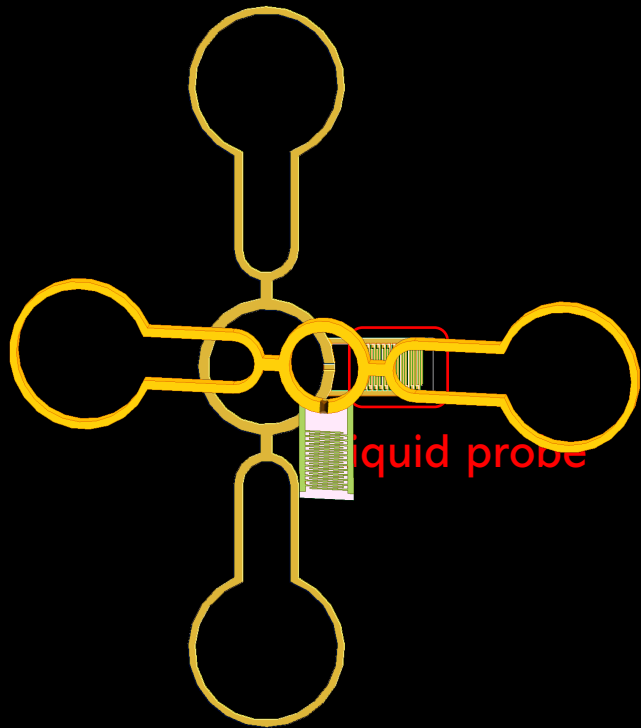

Bovine bone protein solution

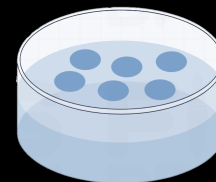
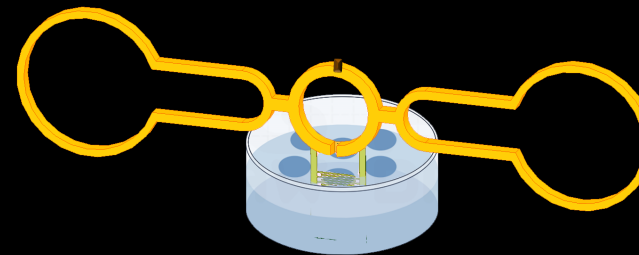
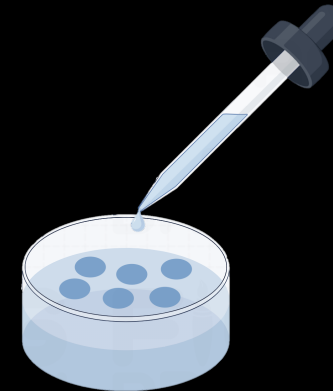

New APP: Liquid Concentration Sensing

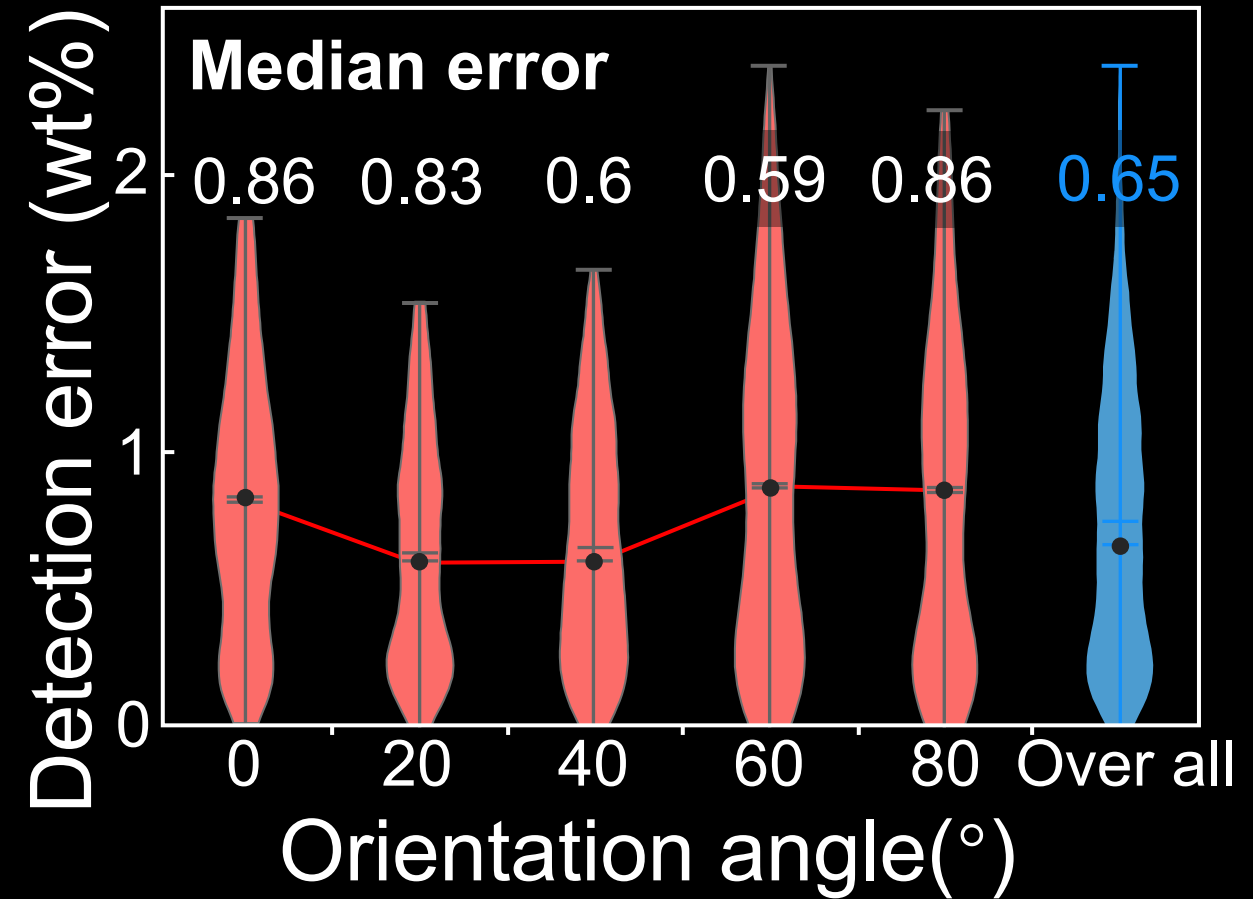
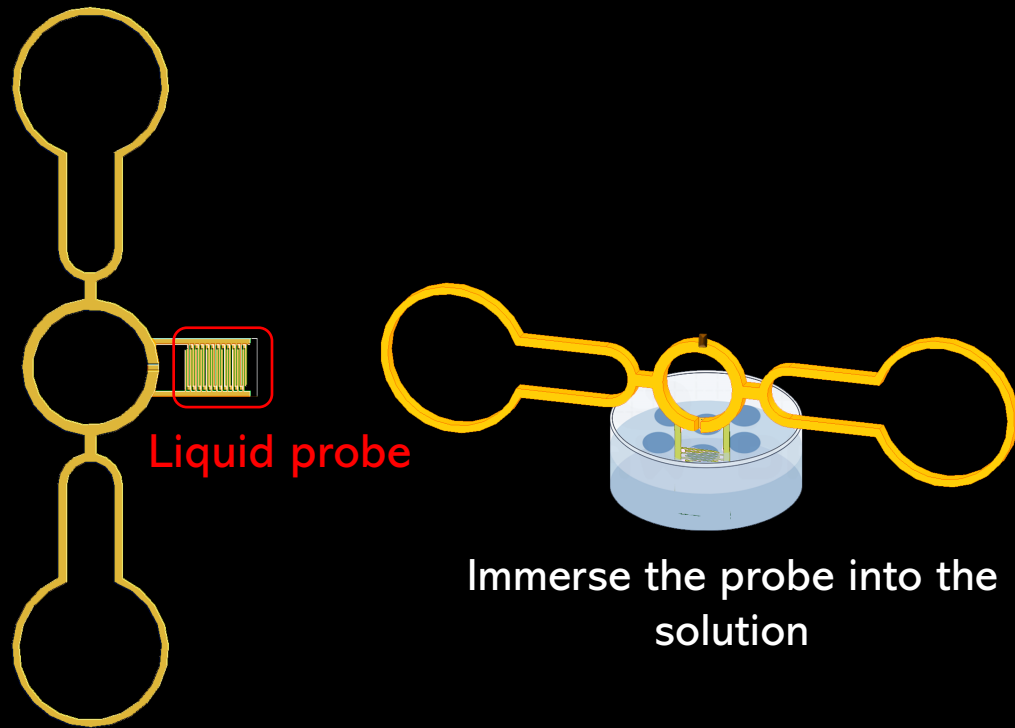

New APP: UV-Light Sensing

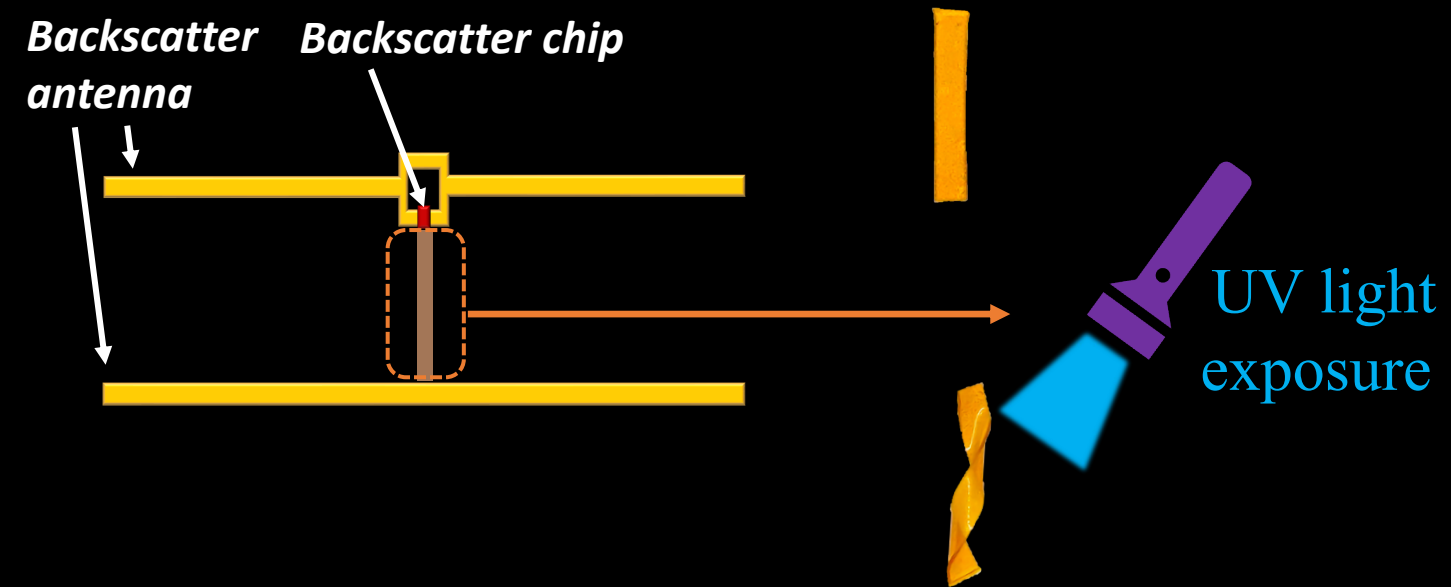

New APP: UV-Light Sensing

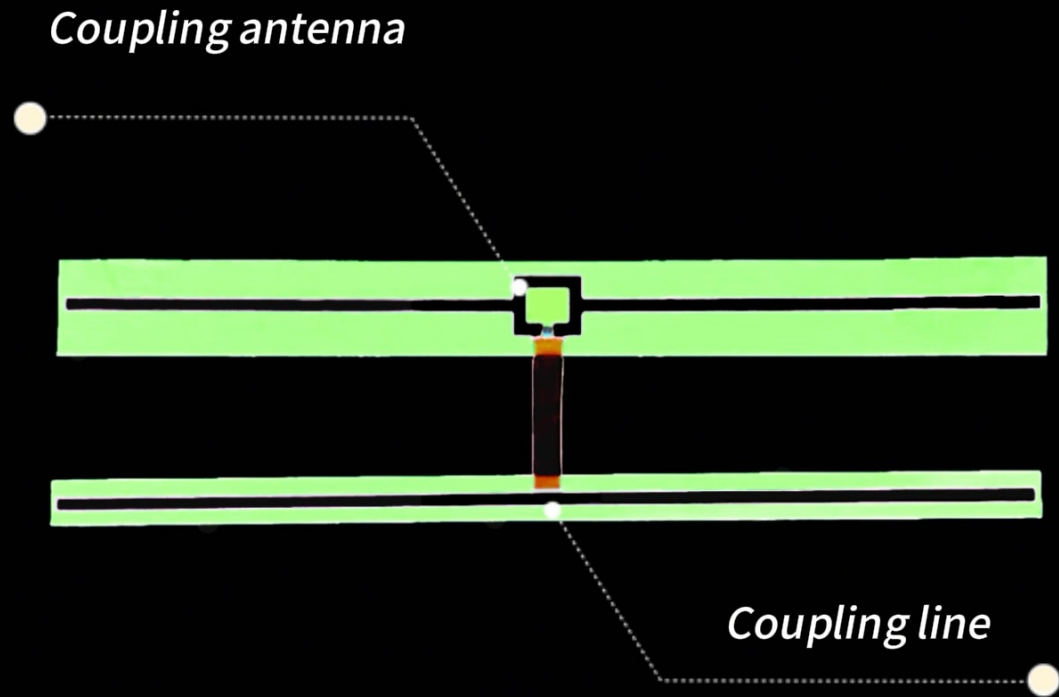
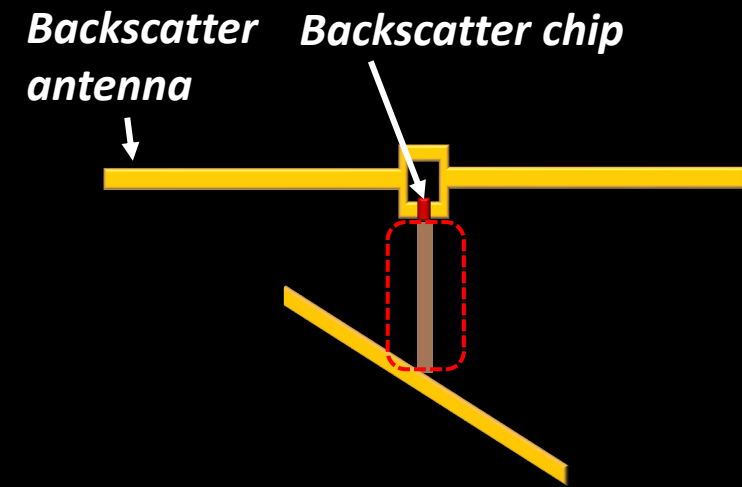

OhmScan tag

New APP: UV-Light Sensing

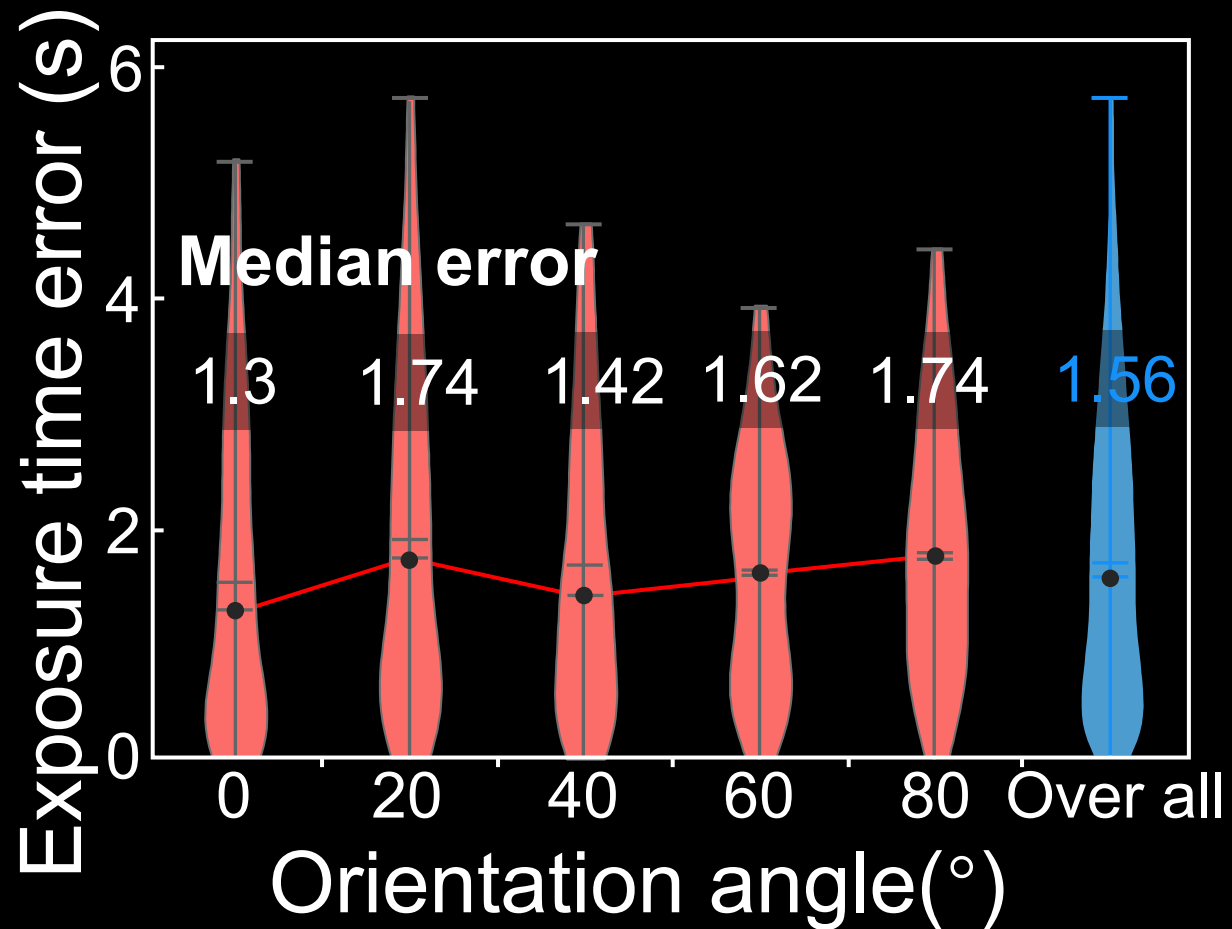
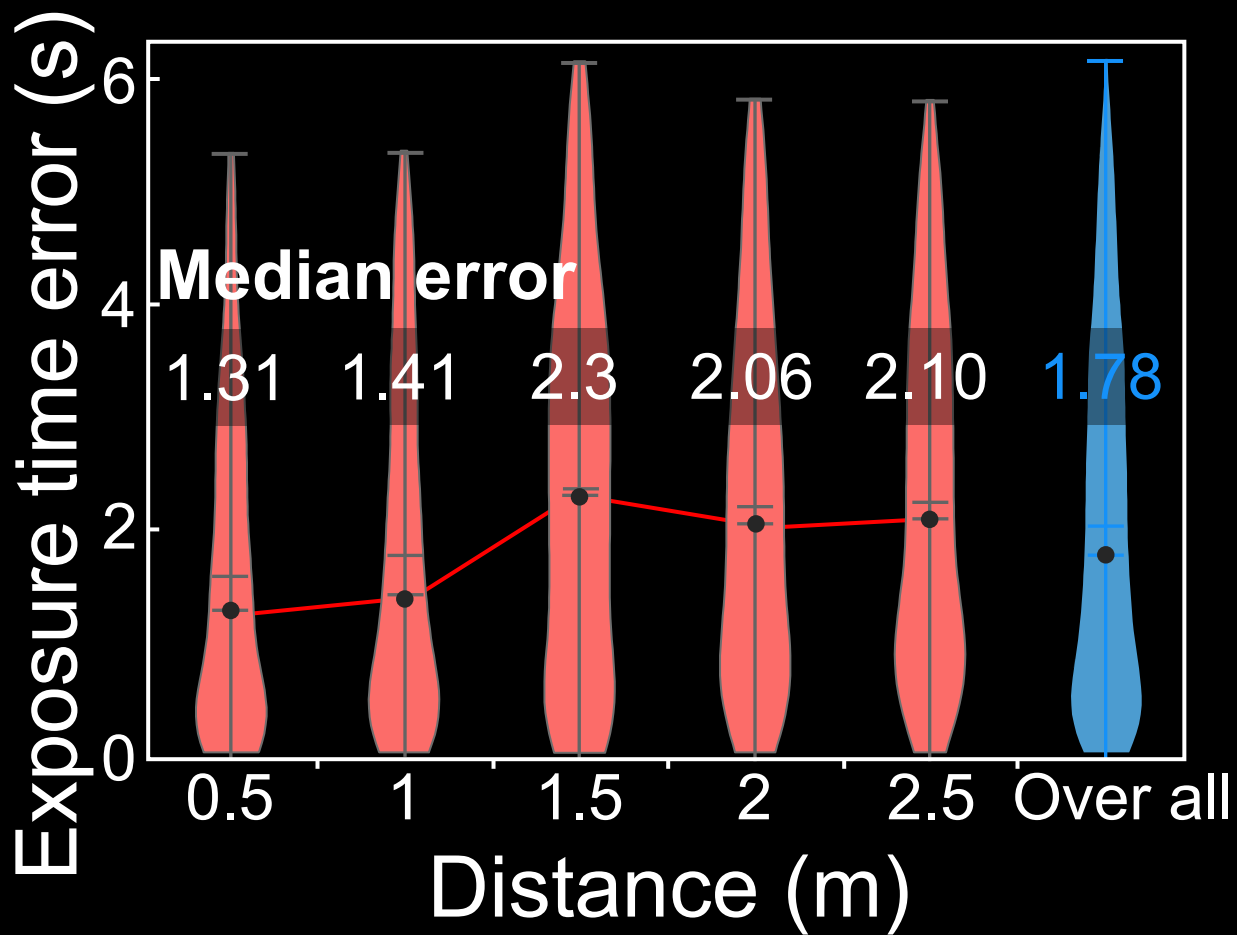

New APP: Pressure Sensing

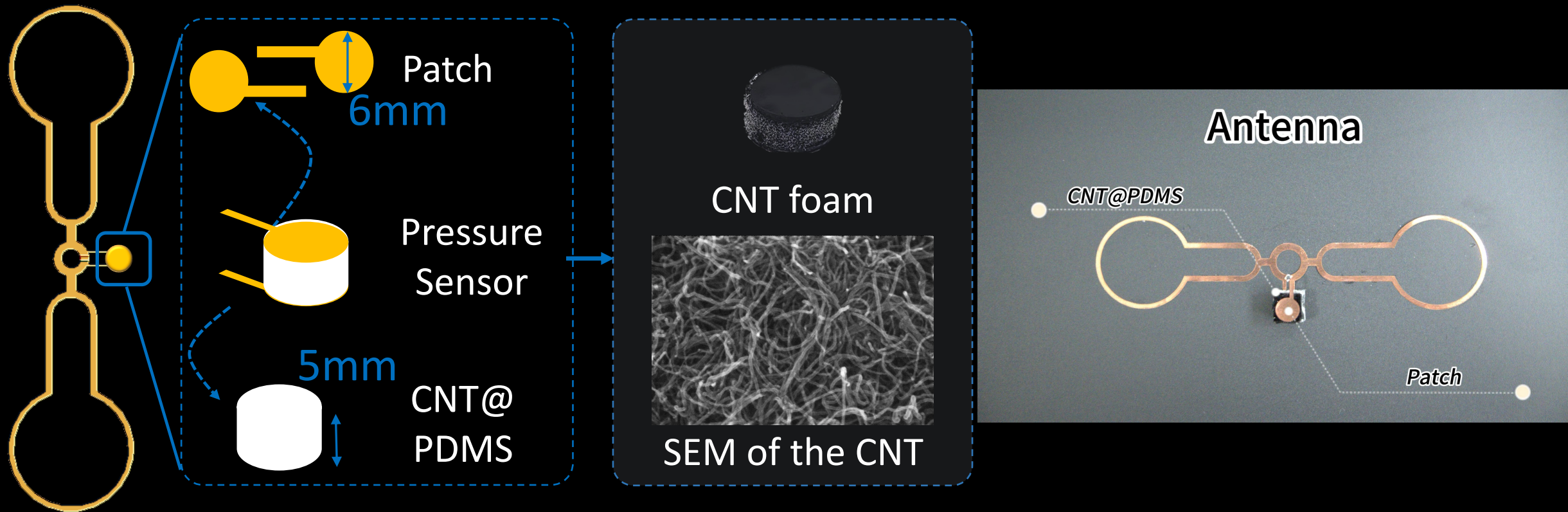

New APP: Pressure Sensing

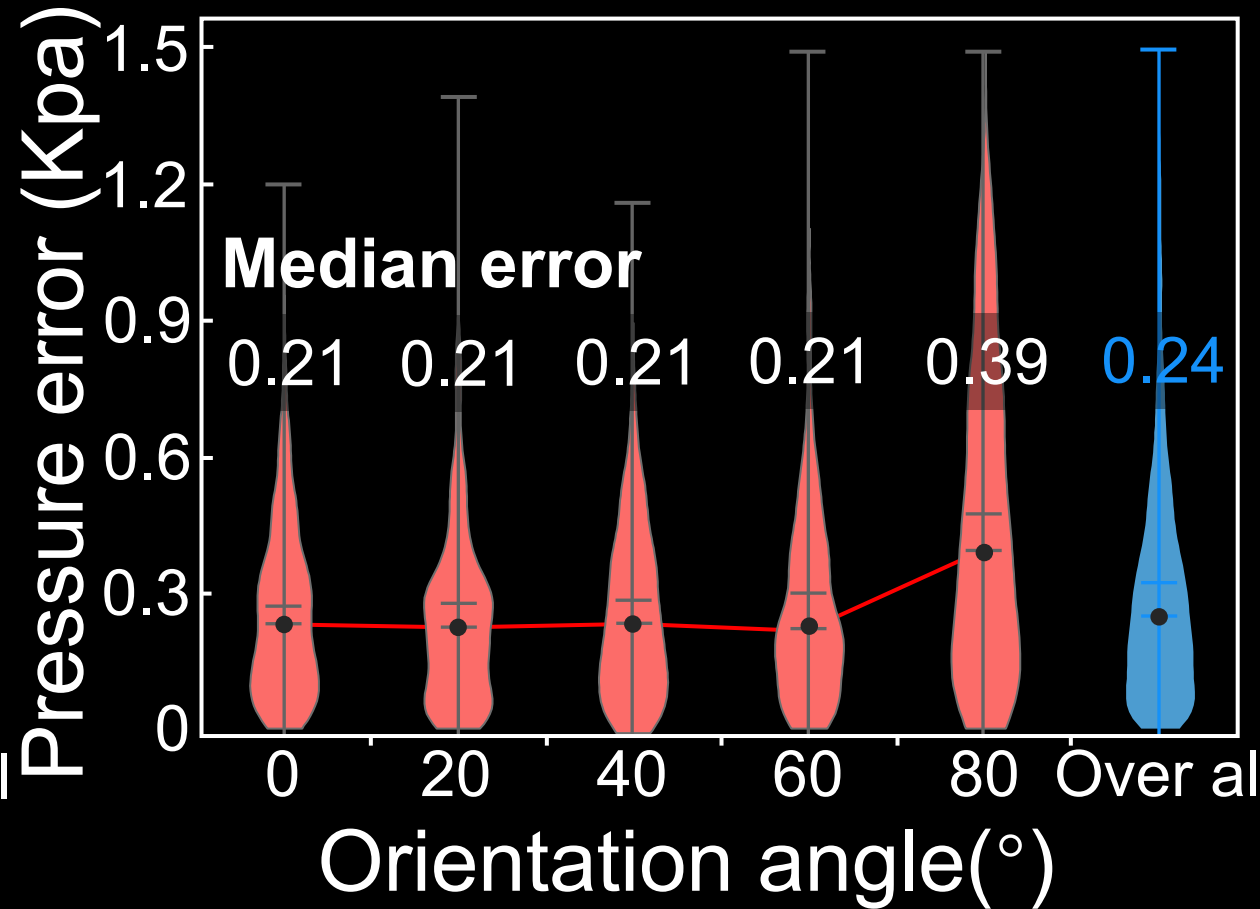
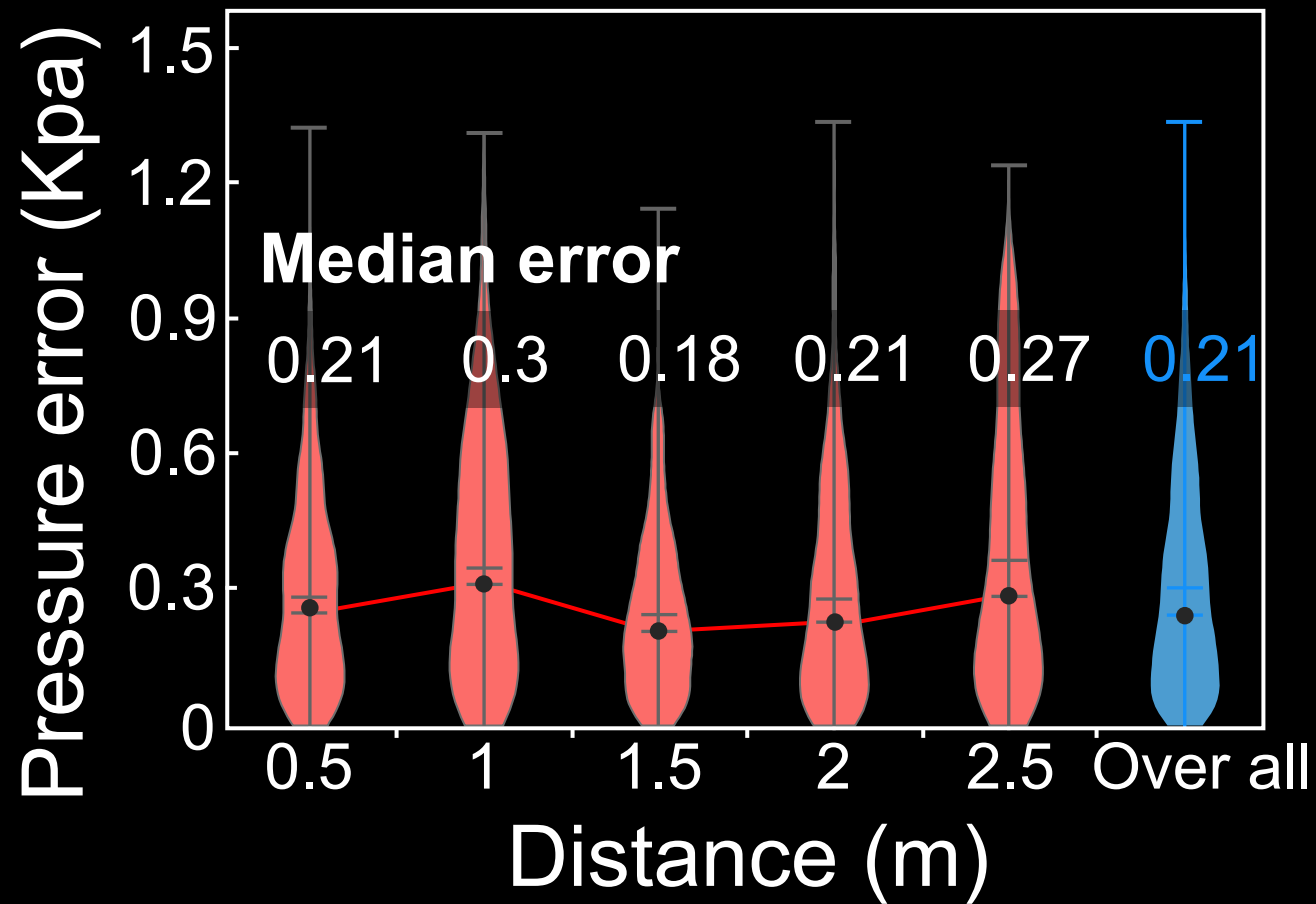

New APP: Temperature Sensing

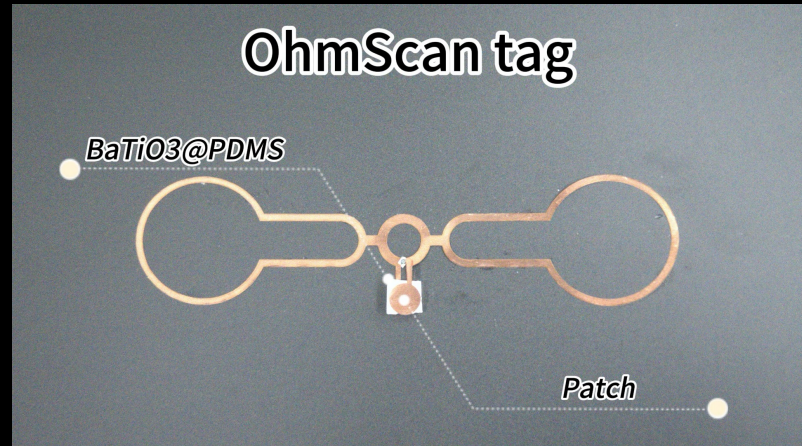
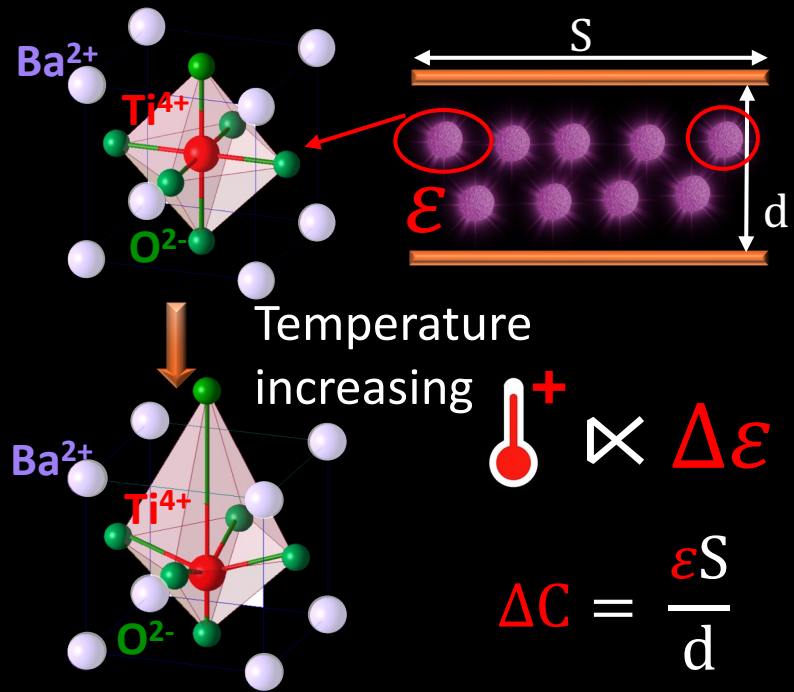
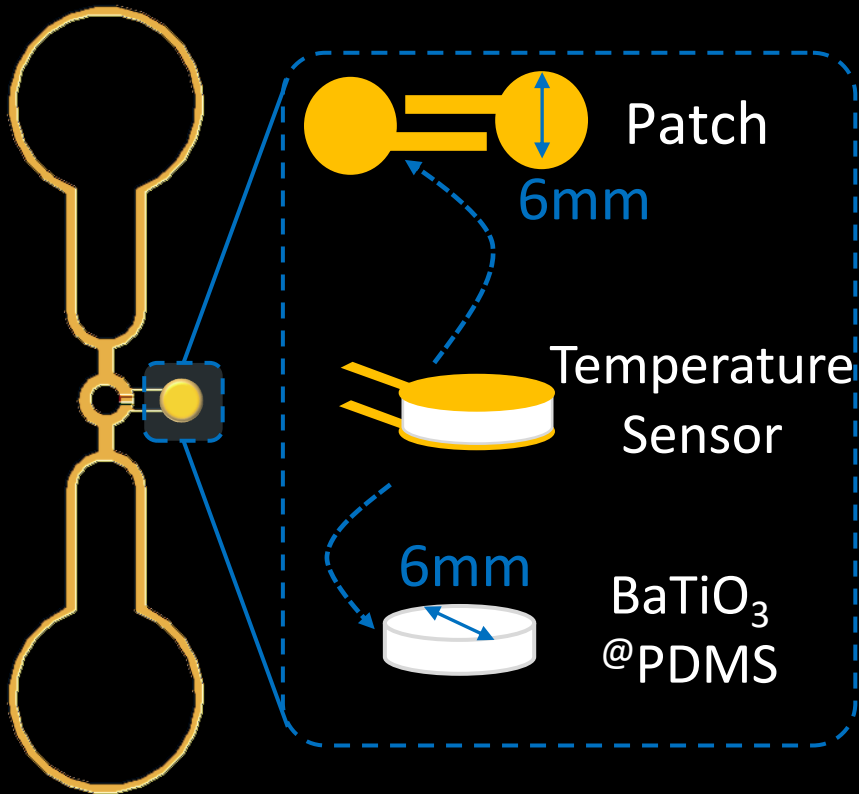

New APP: Temperature Sensing

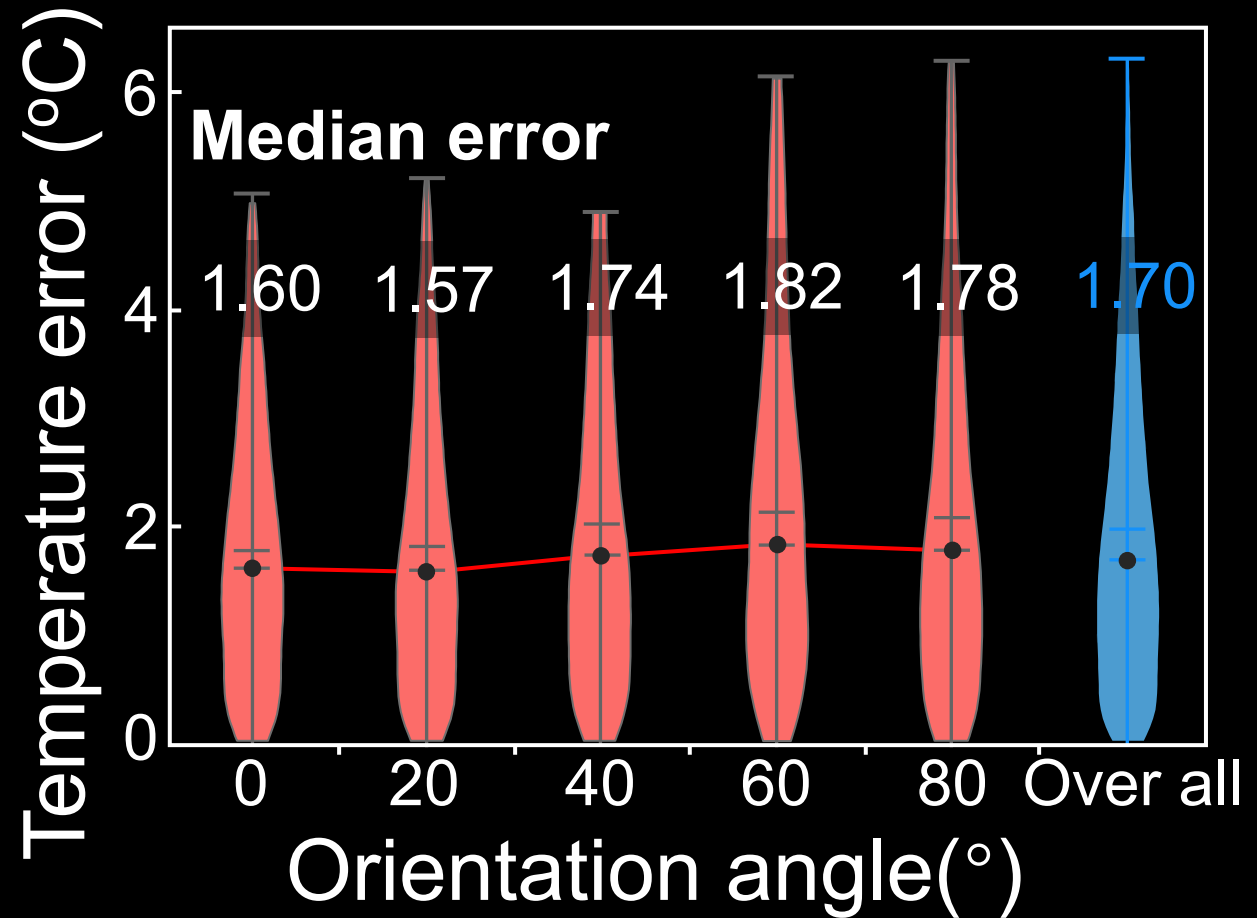
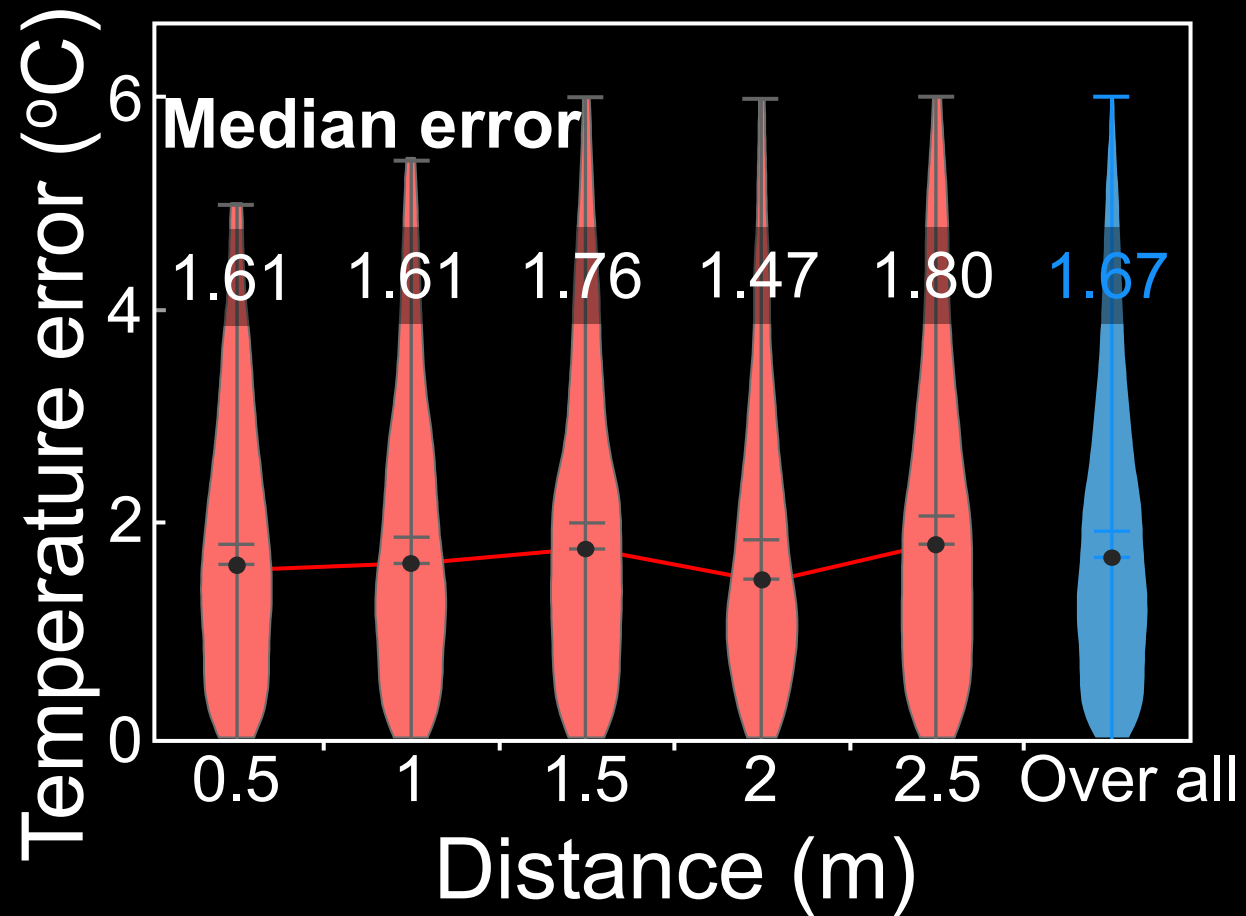

Q & A

From Signal-based to Impedance-based Sensing: A Paradigm Shift for Plug-and-play, Mobile, and Sensitive Battery-free Sensing

